

SF-1

## Single Bar Stack Fold Toolbar

 **BIGHAM**

Bigham Stack Fold Tool Bar technology with patented Stack Lock® wing transport feature is now available in a single bar frame.

The single-bar construction gives you several benefits:

- Lower cost
- Reduced weight and less need for lift-assist wheels
- Mounts closer to tractor for better lifting leverage

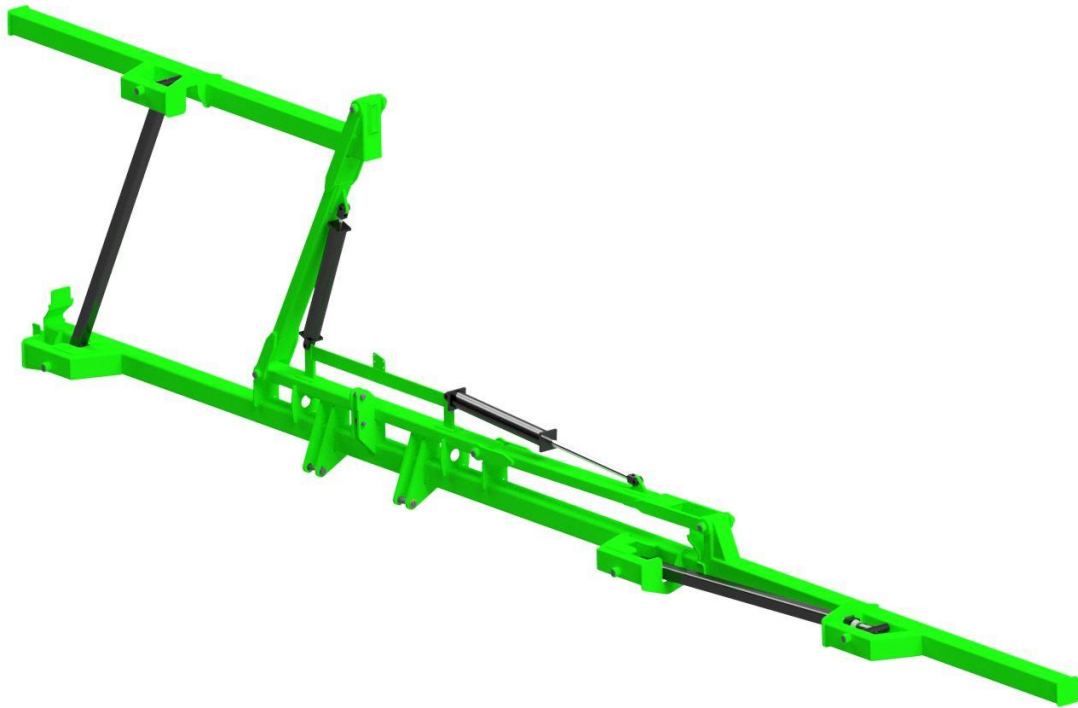

Lubbock, Texas  
Carlisle, Arkansas

(800) 692-4449  
(870) 552-7517

[www.BighamAg.com](http://www.BighamAg.com)



# Single Bar Stack Fold Toolbar



The Single Bar Stack Fold toolbar is recommended for lower load and torque applications such as:

- Planter
- Lilliston Cultivator
- Model 889 Cultivator (up to 12 row)

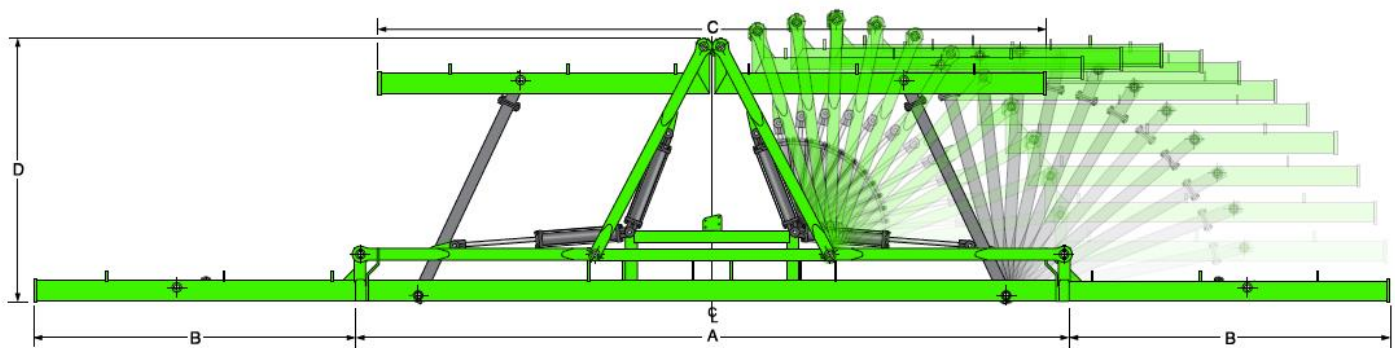

Available sizes range from eight- to sixteen-row 40" lengths. Key Features:

- Folds together and locks into transport position with patented Stack Lock® technology for improved transport safety
- Splined shaft on wings adds "upfloat" on terraced fields or uneven ground to prevent damage or skips
- Lowest transport height and closest mount positioning in the industry
- 3-point hitch in Category 3 or 4
- 2-inch greaseable hinge pins for reliability with steel bushings

For higher load applications like tillage and bedding operations, see our Series III Low Profile Stack Fold



Your Bigham Representative:

